



GAI-TRONICS® CORPORATION
A HUBBELL COMPANY

Model 262-001 and 272-001 Intrinsically-Safe Telephones

Confidentiality Notice

This manual is provided solely as an operational, installation, and maintenance guide and contains sensitive business and technical information that is confidential and proprietary to GAI-Tronics. GAI-Tronics retains all intellectual property and other rights in or to the information contained herein, and such information may only be used in connection with the operation of your GAI-Tronics product or system. This manual may not be disclosed in any form, in whole or in part, directly or indirectly, to any third party.

General Information

The GAI-Tronics Model 262-001 Indoor and Model 272-001 Outdoor Intrinsically-Safe (I.S.) Telephones, and Model 263 Isolation Barrier Units (IBU) are designed to be installed in hazardous areas.

The IBU or rack-mount card unit is placed in a non-hazardous area up to one mile from the telephone. This limits the energy levels going to the hazardous area.

For convenience, an I.S. telephone and the IBU can be purchased together under a single model number—Model 261-001 for indoor use and Model 271-001 for outdoors. However, for rack-mount configurations or special applications, the telephones and IBU can be purchased separately.

These telephones are constructed of durable glass-reinforced polyester, which is highly resistant to chemicals and weather. Both I.S. telephone are rated Type 3R (rainproof).

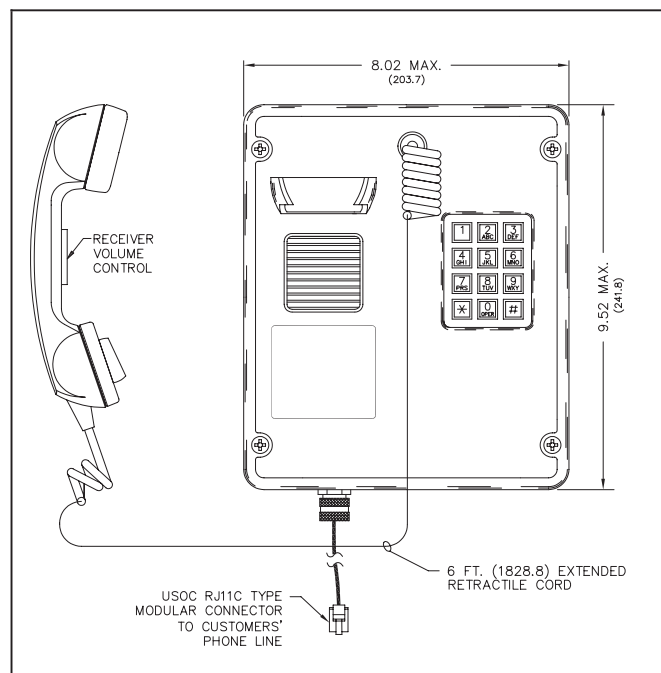

Figure 1. Model 262-001 Intrinsically-Safe Telephone

Installation

Installation Guidelines

When installing any GAI-Tronics telephone equipment, please adhere to the following guidelines to ensure the safety of all personnel:

- NEVER install telephone wiring during a lightning storm.
- **Install a UL Listed lightning arrestor** on any phone installed where the phone or phone cable is at risk of being exposed to lightning strikes. The lightning arrestor must be installed as close to the phone as possible to maximize the protection. The lightning arrestor must not be installed within the enclosure supplied with the phone.
- NEVER install telephone jacks in wet locations unless the jack is specifically designed for wet locations.
- NEVER touch uninsulated telephone wires or terminals unless the telephone line has been disconnected at the network interface.
- USE CAUTION when installing or modifying telephone lines.
- Install UL Listed telephone line suppressor (customer-supplied) on the telephone line.
- Use silicone sealant or equivalent around and inside all conduit entries

Wiring Requirements

Design Limits

In order to be *intrinsically safe*, energy and energy storage must be constrained to “safe” levels in hazardous area apparatus. Wiring inherently has capacitance formed by a dielectric material between two conductors. A buildup of this capacitance can form a surge of electricity, a dangerous situation in a hazardous area.

Intrinsically-safe telephones require cabling that will limit the amount of capacitance formed. The limitation on cable length was set by Underwriter’s Laboratory (UL) based on test results. This “worst case” cable available was found to have a capacitance of 60 picofarads/foot. Therefore, UL set the cable limitation at one mile, the length at which this worst-case cable capacitance level was still within acceptable bounds. Cable types with less capacitance have been specified to allow connection distances over one mile.

For example: GAI-Tronics Model 60059-001 and 60021-301 cables allow connection distances of up to 1.5 miles.

Shielded Cable

Where multiple intrinsically-safe telephone wires are routed together, shielded cable should be used. The use of shielded cable prevents cross-talk from occurring between multiple intrinsically-safe telephone circuits. The shield must be grounded to an intrinsically-safe ground and connected only at the IBU.

Wiring Guidelines/Control Drawing

The Model 262-001 and 272-001 I.S. Telephones must be installed in accordance with GAI-Tronics control drawing 73242 (Pub. 42004-380). In addition, the NEC and the CEC provide additional installation details that are recommended for safe installation.

| General Wire Types | | | | | |
|--|-----------------|--------|--------|--------|--------|
| | 24 AWG | 22 AWG | 20 AWG | 19 AWG | 18 AWG |
| Maximum capacitance, C (picofarads/mile) | 316,800 pF/mile | | | | |
| Maximum resistance, R (ohms/mile) | 271 | 171 | 107 | 85 | 67 |
| *Ring signal loss, decibels (dB/mile) | -16 | -12 | -8 | -6 | -4 |

*Nominal ring signal is 98 dB @ 10 feet.

Installing the Model 262-001 Indoor Telephone

The Model 262-001 Indoor Telephone is intrinsically safe when connected in accordance with GAI-Tronics drawing 73242 (Pub. 42004-380).

1. Carefully loosen the four front panel screws, and slowly remove the front panel assembly.
2. After the front panel is disconnected, put it aside, and mount the enclosure to the wall using four ¼-20 machine screws with nuts and washers or #14 wood screws of the appropriate length depending on the mounting surface. Refer to drawing 73242 (Pub. 42004-380) for details.
3. Feed the wire through the hub at the bottom of the enclosure.
4. Refer to drawing 73242 (Pub. 42004-380) for wiring details.
5. Replace the front panel assembly, and tighten the four front panel screws.



WARNING
Substitution of components may impair intrinsic safety.

Installing the Model 272-001 Outdoor Telephone

The Model 272-001 Outdoor Telephone is intrinsically safe when connected in accordance with GAI-Tronics drawing 73242 (Pub. 42004-380).

1. Open the front door of the enclosure and locate the four outermost screws.
2. Loosen these four screws, and carefully pull the enclosure apart until there is a slight resistance on the left side of the enclosure.
3. Separate the front half of the enclosure from the rear half by pulling on the left side of the enclosure until the hinge plugs pull loose.
4. Put the front half of the enclosure aside, and mount the enclosure to the wall using four ¼-inch screws of the appropriate length, depending on the mounting surface.
5. Feed the station wire through the hub at the bottom of the enclosure.
6. Refer to drawing 73242 (Pub. 42004-380) for wiring details. The station wire is the pair of wires coming directly from the GAI-Tronics Model 263 Isolation Barrier Unit. This unit must not be connected directly to the telephone system.
7. Close the front half of the enclosure, and secure it by tightening the four outermost screws.





WARNING
Substitution of components may impair intrinsic safety.



System Setup

GAI-Tronics recommends taking the following steps to ensure a safe and trouble-free installation:

1. Install the Model 263 Isolation Barrier Unit (IBU) and wire it completely, except for the hazardous area signal wires.

 **WARNING**  **The unit must be wired in accordance with drawing 73242 (Pub. 42004-380) to ensure intrinsic safety.**

2. Next, temporarily connect the I.S. telephone to the IBU with a short pair of conductors, and operate the unit by making a test phone call. If any problems are detected, see the Troubleshooting section.
3. Call the I.S. telephone from another telephone, and adjust the RING PITCH (located on the IBU) to the desired pitch.
4. Disconnect the I.S. telephone and install it in the intended permanent location.

 **WARNING**  **The unit must be wired in accordance with drawing 73242 (Pub. 42004-380) to ensure intrinsic safety.**

5. Make a call from the I.S. telephone. If any problems are detected, see the Troubleshooting section.

External Ringers

The Model 262-001 and 272-001 Intrinsically-Safe Telephones are designed with loud broadcast ringers. In some instances, however, it is advantageous to install external ringers on these units. Examples of such situations include areas where the noise level exceeds 95 dB, and locations where a large area must be covered by a single telephone.

To install an external ringer with the Model 262-001 and 272-001 Telephones, it is necessary to attach an explosion-proof relay to the telephone line. The relay must not interfere with the direct connection between the Model 263 IBU and the intrinsically-safe telephone. The relay must also be wired to an explosion-proof ringer purchased separately by the customer. The customer must install sealed conduit from the relay to the ringer. Refer to Figure 2. Contact your local electrical distributor for information on relays and explosion-proof ringers.

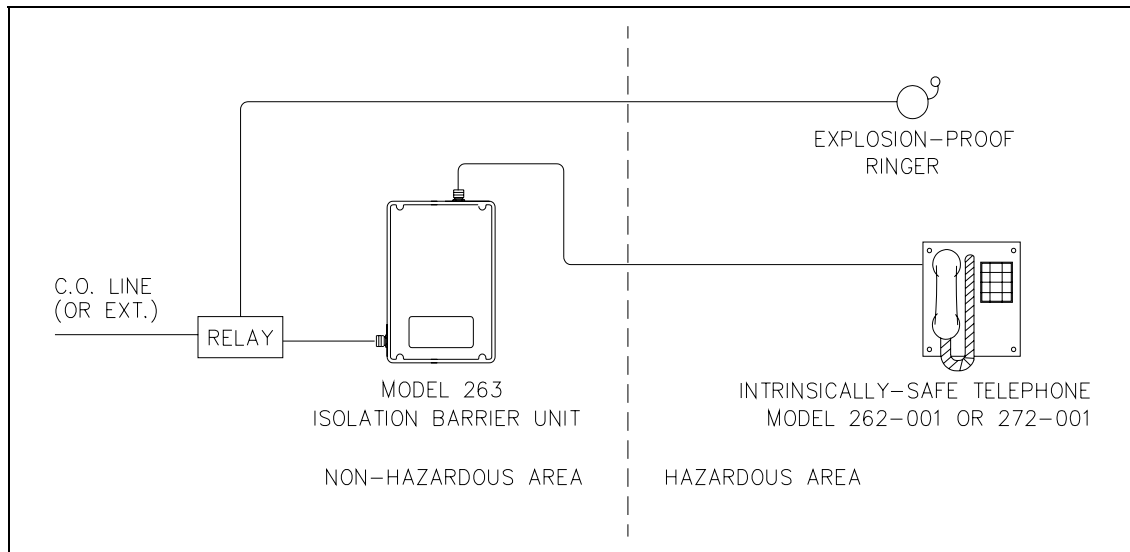

Figure 2. Placement of Explosion-proof Ringer in the Hazardous Area

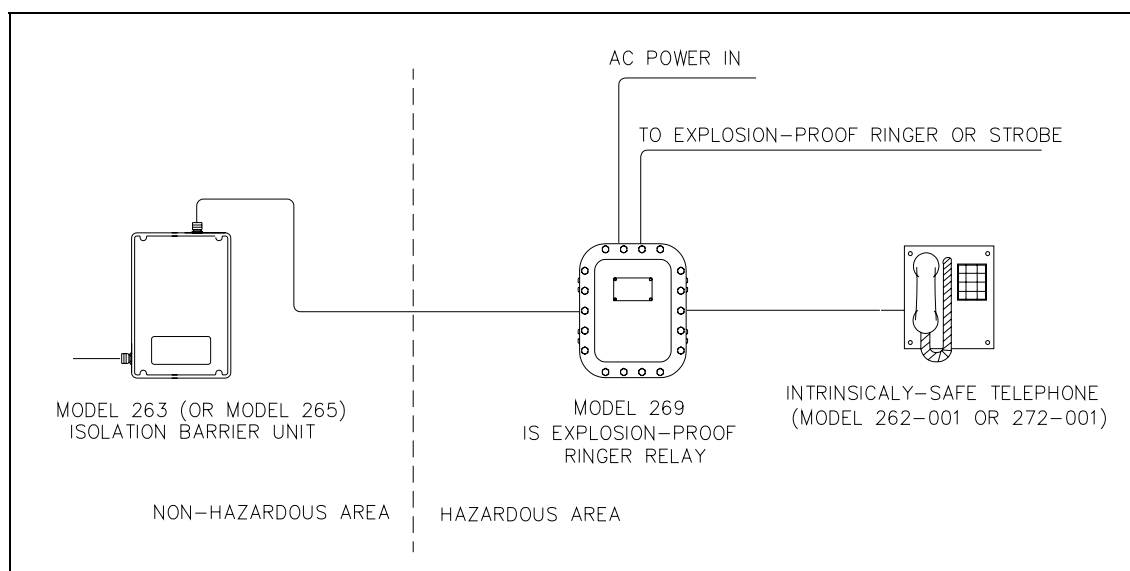

Figure 3. An Alternative Explosion-proof Ringer Placement using a Model 269 I.S. Explosion-Proof Ringer Relay

Operation

1. Lift the I.S. telephone handset to place a call.

2. Adjust handset receiver volume control, if necessary, by pressing the handset pressbar.

NOTE: Pressing the handset pressbar increases the volume in increments of 4 dB. The volume starts at 0 dB and increases to a maximum volume of 8 dB. Pressing the pressbar a fourth time will return the volume to -4 dB. Pressing the pressbar one more time will return the gain to 0 dB.

3. Dial the desired number.

4. After completion of the call, place the handset on-hook.

Maintenance

This section includes two troubleshooting charts designed to quickly pinpoint the source of problems.

Troubleshooting

NOTE: It may be advantageous to temporarily connect a Model 262-001 or 272-001 Telephone panel directly to the output terminals of the Model 263 IBU when troubleshooting. Then, using the charts below, the cause of the problem should more easily be determined.

Non-Equipment Related Problems

| Problem | Solution | | | | | | | | |
|--|---|--------|------|---|------|-------|-------|---|---|
| The I.S. phone is inactive with no lights on the IBU when the phone is off-hook. | <ol style="list-style-type: none"> 1. Check the ac power to the Model 263 IBU. 2. Check the ac fuse F4 at the Model 263 IBU. 3. Ensure there is no wiring open at the I.S. phone. | | | | | | | | |
| The I.S. phone has no dial tone. | <ol style="list-style-type: none"> 1. If the I.S. phone has a wiring short, the IBU lights will be lit in the following pattern: ● = On, ○ = Off <table style="margin-left: 40px;"> <tr> <td>ISLOOP</td> <td>LOCK</td> </tr> <tr> <td>●</td> <td>○</td> </tr> <tr> <td>HOOK</td> <td>TELCO</td> </tr> <tr> <td>○</td> <td>○</td> </tr> </table> | ISLOOP | LOCK | ● | ○ | HOOK | TELCO | ○ | ○ |
| | ISLOOP | LOCK | | | | | | | |
| ● | ○ | | | | | | | | |
| HOOK | TELCO | | | | | | | | |
| ○ | ○ | | | | | | | | |
| <ol style="list-style-type: none"> 2. If the TELCO line has an open, the IBU lights will be lit in the following pattern: ● = On, ○ = Off <table style="margin-left: 40px;"> <tr> <td>ISLOOP</td> <td>LOCK</td> </tr> <tr> <td>●</td> <td>●</td> </tr> <tr> <td>HOOK</td> <td>TELCO</td> </tr> <tr> <td>●</td> <td>○</td> </tr> </table> | ISLOOP | LOCK | ● | ● | HOOK | TELCO | ● | ○ | |
| ISLOOP | LOCK | | | | | | | | |
| ● | ● | | | | | | | | |
| HOOK | TELCO | | | | | | | | |
| ● | ○ | | | | | | | | |
| The lights on the IBU flash randomly. | The I.S. phone has an intermittent wiring short. The short may be between the conductors or either/both conductor(s) to ground/shield. | | | | | | | | |

Equipment-Related Problems

| Problem | Solution |
|---|--|
| There is no incoming ring tone. | <ol style="list-style-type: none"> 1. Check the I.S. telephone panel. 2. Check the Model 263 IBU. |
| No receiver audio, no sidetone, and cannot hear touch tones when pressed. | <ol style="list-style-type: none"> 1. Check the I.S. telephone panel. 2. Check the Model 263 IBU. 3. There may be a wiring open or a short in the connecting cable. |
| Cannot dial out, but can hear touch tones when pressed. | <ol style="list-style-type: none"> 1. Check the Model 263 IBU. 2. There is no TELCO connection or it is faulty. |
| I.S. phone appears inactive. | <ol style="list-style-type: none"> 1. Check the I.S. telephone panel. 2. Check the Model 263 IBU. 3. Ensure there is no wiring open in the connecting cable or at the I.S. phone. |

 **CAUTION** 

Any field repairs on the intrinsically-safe design of the phone are strictly prohibited. Any such change will void ALL hazardous approvals. Please contact the GAI-Tronics Field Service Department at 800-492-1212 inside the USA, or 610-777-1374 outside the USA, for the Regional Service Center closest to you.

Lightning Protection

Telephone lines are susceptible to lightning strikes and must be properly protected and maintained. On-premise line protection is usually provided at the building entrance by the responsible telephone company when installed. It is common that this protection is neglected after installation.

Degradation of conventional protection, such as carbon blocks or gas discharge types, will occur with each lightning strike. To ensure safe operation, protective elements should be replaced frequently and checked for proper connection and grounding. Gas discharge types are by far the most robust, cost-effective means of protection.

The registered I.S. equipment meets all isolation and safety requirements of FCC, Part 68, DOC CS-03, UL 913, and CSA C22.2-No. 157; however, lightning strikes are not predictable or considered to be a condition of fault likely to occur in practice as defined by the guidelines for intrinsic safety. Therefore, it is imperative that the user employ and maintain a proper lightning protection scheme. This is true for all hazardous area equipment and all telecommunications equipment subject to lightning.

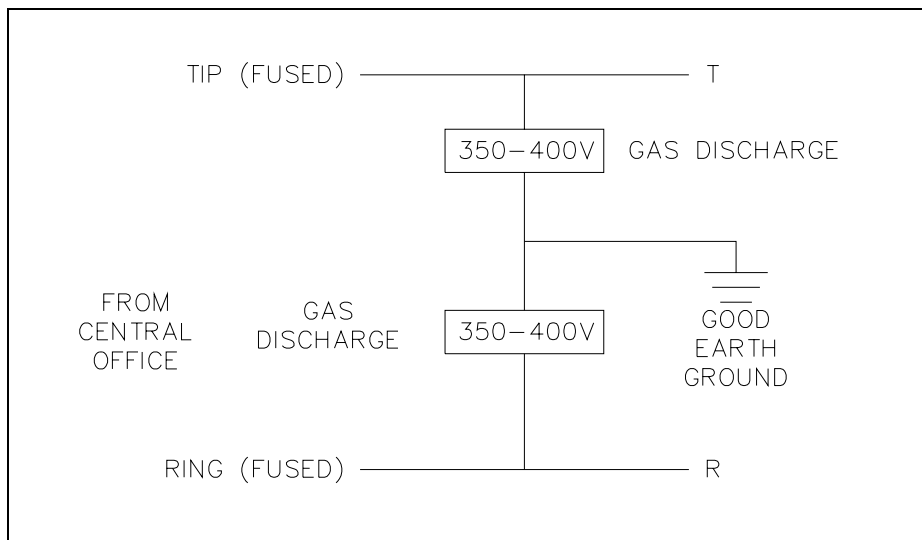

Figure 4. Example of Lightning Protection Design

Specifications

General/Environmental

| | |
|---|--|
| Location (Model 263 IBU) | Ordinary (non-classified) indoor/outdoor |
| FCC Registration Number | ADGUSA-65066-TE-E |
| Ringer Equivalence Number (REN) | 0.4B |
| IC Certification Number (Canada)..... | 822 4541 A |
| Load number (LN) (Canada)..... | 14 |
| Connecting method (Canada)..... | CA11A |
| Operating temperature range..... | -40° F to +140° F (-40° C to +60° C) |
| Relative humidity | 95% (non-condensing) maximum |
| Maximum safe wiring distance between IBU and I.S. telephone | |
| Standard wire types..... | 1 mile |
| Using GTC 60059-001 conductor..... | 1.5 miles |
| Using GTC 60021-301 conductor..... | 1.5 miles |

Wiring

| | |
|---------------------------------------|--------------|
| Construction..... | Twisted pair |
| *Type | Shielded |
| Conductor size (minimum) | 24 AWG |
| Wiring loop resistance (maximum)..... | 275 ohms |
| Wiring capacitance (maximum)..... | 0.316 uF |

*Shielded cable is required where multiple I.S. telephone wires are routed together.

Model 263 Isolation Barrier Unit

Electrical /Acoustical

Telephone Network Interface.....(2-wire) BELL Pub. 61100 Compatible
(4-wire) See 4-wire option below

AC power input..... Voltage (selectable) 90–132 V
180–240 V

Frequency..... 47–63 Hz

Current 0.5 amps (maximum)

Ringer pitch adjust 1–8 kHz (nominal)

Intrinsically safe Interface

Voltage (maximum)..... 8 volts

Resistance (minimum) 66 ohms

Current limited (maximum) 136 mA

Indicators

I.S. Loop Current I.S. LOOP (GRN)

I.S. Lock Detect I.S. LOCK (GRN)

Telephone line loop current TELCO (YEL)

Hook..... HOOK (YEL)

Mechanical

Housing construction Glass-reinforced polyester

Housing dimensions..... 9.39 W × 13.16 H × 7.46 D inches; (238.5 × 334.3 × 189.5 mm)

Enclosure rating Type 3R (rainproof)

Weight 8.5 lbs. (3.86 kg)

4-Wire Option - Model 263 IBU Interface Specifications

Receive (TB2-1, 2)..... Dry (No dc)

Signal level 0 dBm (nominal)
+3 dBm (maximum)

Transmit (TB2-3, 4)..... Wet

DC loop current 20–70 mA

Signal level 0 dBm (nominal)

Ring voltage input..... 40–150 Vrms

Model 262-001 Indoor /Model 272-001 Outdoor I.S. Telephones

Electrical /Acoustical

| | |
|--|------------------------------|
| Electrical specifications (nominal)..... | 12 V, 12 mA |
| Ringer performance (typical)..... | 98 dB @ 10 feet |
| Frequency (adjustable at the IBU) | 1–8 kHz (typical) |
| Ring signal loss (18 AWG)..... | -4 dB/mile |
| Signaling | DTMF |
| Transmission path (2-conductor) | Full duplex |
| Microphone | Dynamic noise-canceling |
| Earpiece..... | Hearing aid compatible (HAC) |
| Output (0 dBm @ IBU TELCO Line) | 105 dB SPL @ 1 kHz |
| Audio signal loss (18 AWG)..... | -1.3 dB/mile |

NOTE: Must be connected in accordance with GAI-Tronics drawing 73242 (Pub. 42004-380).

Mechanical

Housing construction Glass-reinforced polyester

Housing dimensions

| | |
|--------------------|---|
| Model 262-001..... | 8.02 W × 9.52 H × 6.86 D inches; (203.7 × 241.8 × 174.2 mm) including handset; 3.86 D (98 mm), without handset |
| Model 272-001..... | 9.39 W × 13.16 H × 7.46 D inches; (238.5 × 334.3 × 189.5 mm) |

Enclosure rating (UL)

| | |
|--------------------|---------------------|
| Model 262-001..... | Type 12 |
| Model 272-001..... | Type 3R (rainproof) |

Weight

| | |
|--------------------|---------------------|
| Model 262-001..... | 5.0 lbs. (2.27 kg) |
| Model 272-001..... | 10.0 lbs. (4.53 kg) |

Approvals

When connected according to GAI-Tronics drawing 73242 (Pub. 42004-380):

| | |
|-------------|--|
| UL/cUL..... | Class I, Div. 1, Groups A, B, C, and D; Class II, Div. I, Groups E, F, and G; Class III |
|-------------|--|

Replacement Parts

| Part Number | Description |
|-------------|--|
| 12513-002 | Mid/Rear Enclosure Replacement Kit (Model 272-001) |
| 12513-006 | Door Replacement Kit |
| 12575-007 | Rear Enclosure Replacement Kit (Model 262-001) |
| 14242-016 | Rear Enclosure Replacement Kit (Model 262-001) |
| 25701-002 | Latch Replacement Kit |
| 25701-003 | Lock Replacement Kit |

Warranty

Equipment. GAI-Tronics warrants for a period of one (1) year from the date of shipment, that any GAI-Tronics equipment supplied hereunder shall be free of defects in material and workmanship, shall comply with the then-current product specifications and product literature, and if applicable, shall be fit for the purpose specified in the agreed upon quotation or proposal document. If (a) Seller's goods prove to be defective in workmanship and/or material under normal and proper usage, or unfit for the purpose specified and agreed upon, and (b) Buyer's claim is made within the warranty period set forth above, Buyer may return such goods to GAI-Tronics nearest depot repair facility, freight prepaid, at which time they will be repaired or replaced, at Seller's option, without charge to Buyer. Repair or replacement shall be Buyer's sole and exclusive remedy, and the warranty period on any repaired or replacement equipment shall be one (1) year from the date the original equipment was shipped. In no event shall GAI-Tronics warranty obligations with respect to equipment exceed 100% of the total cost of the equipment supplied hereunder. Buyer may also be entitled to the manufacturer's warranty on any third-party goods supplied by GAI-Tronics hereunder. The applicability of any such third-party warranty will be determined by GAI-Tronics.

Services. Any services GAI-Tronics provides hereunder, whether directly or through subcontractors, shall be performed in accordance with the standard of care with which such services are normally provided in the industry. If the services fail to meet the applicable industry standard, GAI-Tronics will, for a period of one (1) year from the date of completion, re-perform such services at no cost to Buyer. Re-performance of services shall be Buyer's sole and exclusive remedy, and in no event shall GAI-Tronics warranty obligations with respect to services exceed 100% of the total cost of services provided hereunder.

Warranty Periods. Every claim by Buyer alleging a defect in the goods and/or services provided hereunder shall be deemed waived unless such claim is made in writing within the applicable warranty periods as set forth above. Provided, however, that if the defect complained of is latent and not discoverable within the above warranty periods, every claim arising on account of such latent defect shall be deemed waived unless it is made in writing within a reasonable time after such latent defect is or should have been discovered by Buyer.

Limitations / Exclusions. The warranties herein shall not apply to, and GAI-Tronics shall not be responsible for, any damage to the goods or failure of the services supplied hereunder, to the extent caused by Buyer's neglect, failure to follow operational and maintenance procedures provided with the equipment, or the use of technicians not specifically authorized by GAI-Tronics to maintain or service the equipment. **THE WARRANTIES AND REMEDIES CONTAINED HEREIN ARE IN LIEU OF AND EXCLUDE ALL OTHER WARRANTIES AND REMEDIES, WHETHER EXPRESS OR IMPLIED BY OPERATION OF LAW OR OTHERWISE, INCLUDING ANY WARRANTIES OF MERCHANTABILITY OR FITNESS FOR A PARTICULAR PURPOSE.**

Return Policy

If the equipment requires service, contact your Regional Service Center for a return authorization number (RA#). Equipment should be shipped prepaid to GAI-Tronics with a return authorization number and a purchase order number. If the equipment is under warranty, repairs or a replacement will be made in accordance with the warranty policy set forth above. Please include a written explanation of all defects to assist our technicians in their troubleshooting efforts.

Call 800-492-1212 (inside the USA) or 610-777-1374 (outside the USA) for help identifying the Regional Service Center closest to you.