



GAI-TRONICS® CORPORATION
A HUBBELL COMPANY

Model 13360 and 13361 Clean Room Speakers

Confidentiality Notice

This manual is provided solely as an operational, installation, and maintenance guide and contains sensitive business and technical information that is confidential and proprietary to GAI-Tronics. GAI-Tronics retains all intellectual property and other rights in or to the information contained herein, and such information may only be used in connection with the operation of your GAI-Tronics product or system. This manual may not be disclosed in any form, in whole or in part, directly or indirectly, to any third party.

General Information

The Model 13360 and 13361 Clean Room Speakers are ideal for clean room environments. The speakers are designed to provide outstanding voice reproduction for use in public address and general alarm applications.

The units can be ceiling-mounted or flush-mounted into a wall. The completely smooth front panel is sealed with a polyester overlay that allows for wash-downs while keeping the speaker particulate-free. The back box is fabricated from stainless steel. The Model 13360 operates at an 8-ohm impedance, and the Model 13361 has a 70 V line-matching transformer.

The speakers are designed to withstand exposure to many chemicals. See a partial listing below:

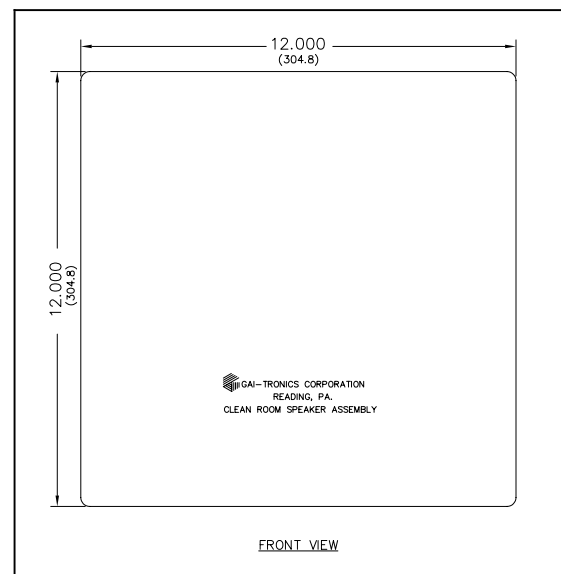

Clean Room Speaker Outline Drawing

Isopropanol	Aliphatic hydrocarbons	Chlorofluorohydrocarbons
Methanol	Xylene	Phosphoric acid <30%
Benzene	Trichlorethylene	Hydrochloric acid <30%
Water <100° F	Ammonia <2%	Nitric acid <10%
Acetone	Washing powders	Sodium hypochlorite <20%
Alkal carbonate	Caustic soda <2%	
Hydrogen peroxide 25%	Toluene	

Installation

The dimensions for the cut-out template for the ceiling or wall mounting are provided below. A full scale template is packed with the speaker at the factory. The back box depth is 3.5 inches.

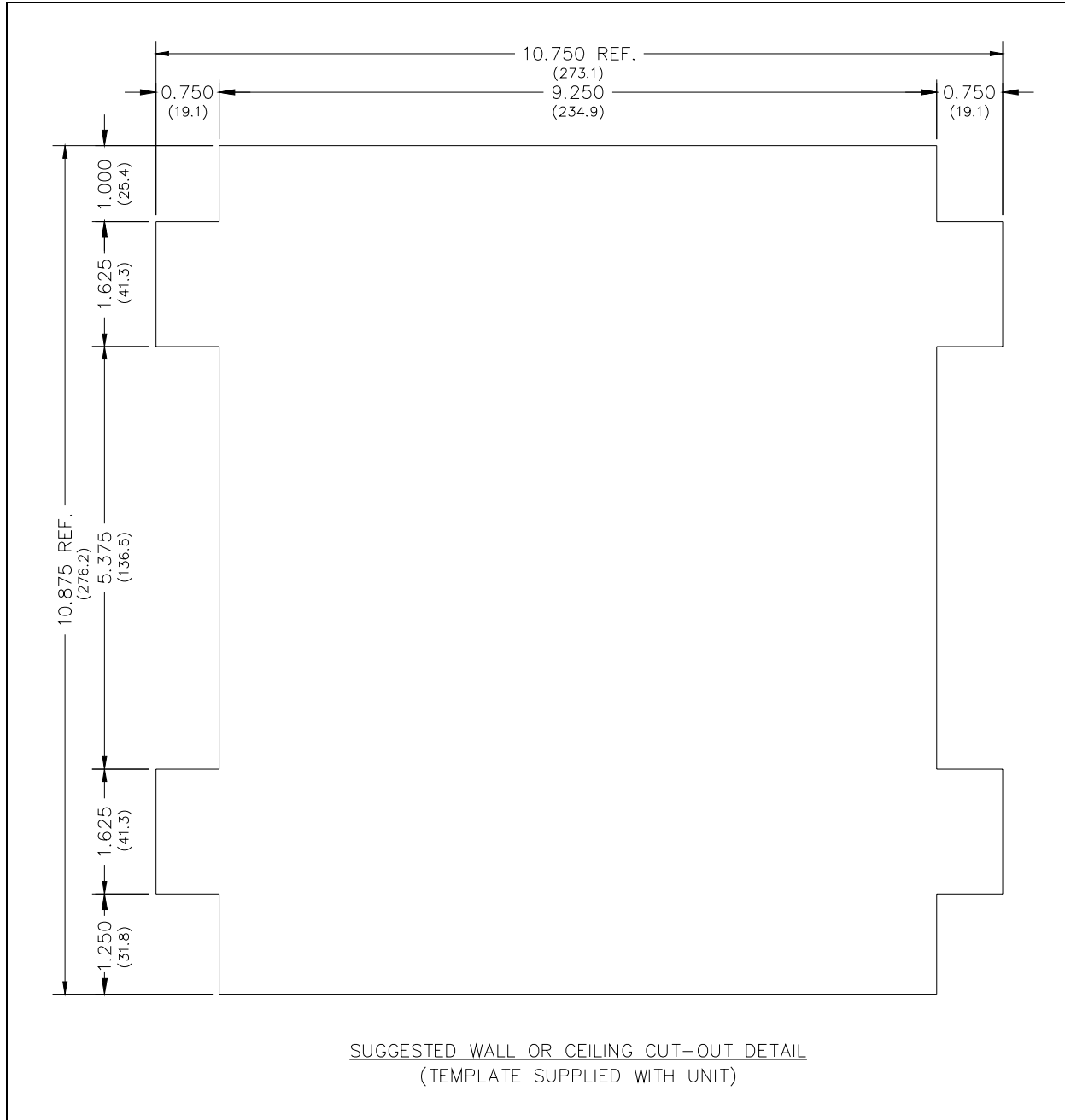

Figure 1. Cut-out template dimensions

Wiring

Please refer to the typical wiring configurations for the Model 13361 and Model 13360 Clean Room Speaker shown in Figure 2 and Figure 3 below:

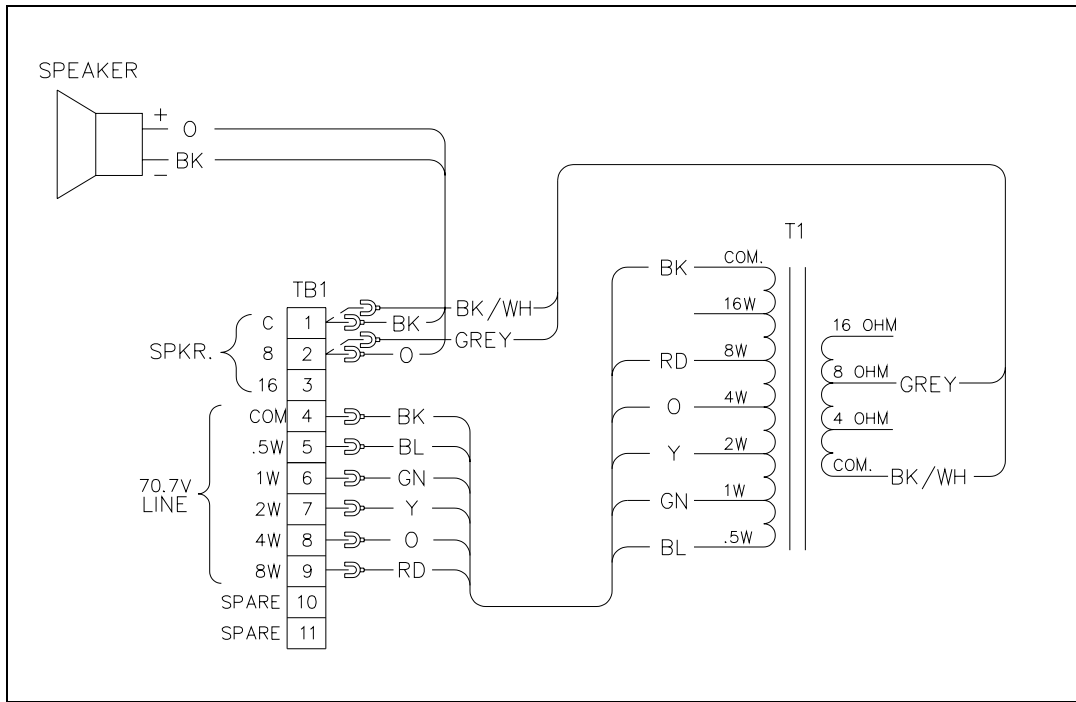

Figure 2. Typical wiring configuration for Model 13361 Clean Room Speaker

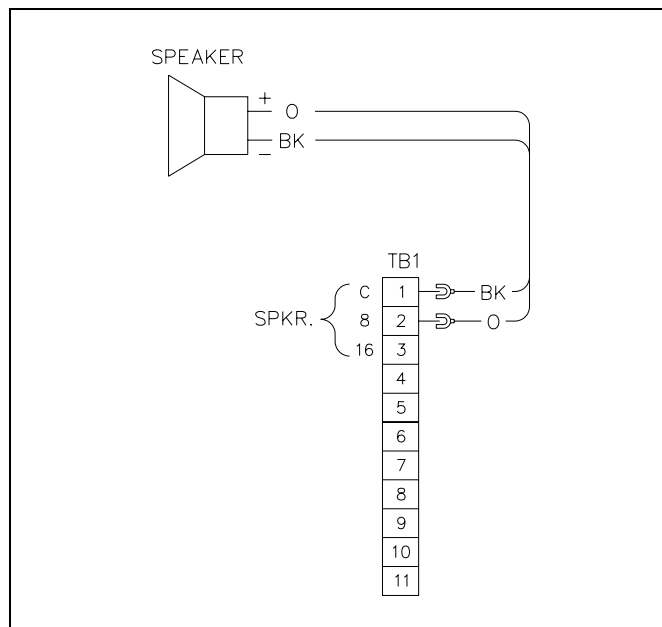

Figure 3. Typical wiring configuration for Model 13360 Clean Room Speaker

Specifications

Electrical

Power

Model 13360..... 8 watts continuous

Model 13361..... 8 watts maximum (user adjustable taps)

Impedance

Model 13360..... 8 ohms

Model 13361..... 70.7 volt, line-matching transformer

Sensitivity 102 dB (1 watt @ 1 meter)

Frequency response..... 410 Hz to 4200 Hz, +/-6 dB

Dispersion 180° @ 1 kHz

Mechanical

Mounting..... Ceiling or wall flush-mount

Dimensions

Front panel..... 12.0 W × 12.0 H inches (305 × 305 mm)

Back box/Mounting bracket 10.75 W × 10.75 H × 3.5 D inches (273.1 × 273.1 × 88.9 mm)

Construction

Front panel..... 8 mil polyester over 16-gauge stainless steel

Back box/Mounting bracket 16-gauge stainless steel

Net weight..... 11 lbs. (4.99 kg)

Replacement Parts

Part No.	Description	13360	13361
13327-021	Speaker, weatherproof, 5-inch, 16-watt, 8-ohm	■	■
56133-007	Transformer, speaker match, 8-watt, 70V		■

Warranty

Equipment. GAI-Tronics warrants for a period of one (1) year from the date of shipment, that any GAI-Tronics equipment supplied hereunder shall be free of defects in material and workmanship, shall comply with the then-current product specifications and product literature, and if applicable, shall be fit for the purpose specified in the agreed upon quotation or proposal document. If (a) Seller's goods prove to be defective in workmanship and/or material under normal and proper usage, or unfit for the purpose specified and agreed upon, and (b) Buyer's claim is made within the warranty period set forth above, Buyer may return such goods to GAI-Tronics nearest depot repair facility, freight prepaid, at which time they will be repaired or replaced, at Seller's option, without charge to Buyer. Repair or replacement shall be Buyer's sole and exclusive remedy, and the warranty period on any repaired or replacement equipment shall be one (1) year from the date the original equipment was shipped. In no event shall GAI-Tronics warranty obligations with respect to equipment exceed 100% of the total cost of the equipment supplied hereunder. Buyer may also be entitled to the manufacturer's warranty on any third-party goods supplied by GAI-Tronics hereunder. The applicability of any such third-party warranty will be determined by GAI-Tronics.

Services. Any services GAI-Tronics provides hereunder, whether directly or through subcontractors, shall be performed in accordance with the standard of care with which such services are normally provided in the industry. If the services fail to meet the applicable industry standard, GAI-Tronics will, for a period of one (1) year from the date of completion, re-perform such services at no cost to Buyer. Re-performance of services shall be Buyer's sole and exclusive remedy, and in no event shall GAI-Tronics warranty obligations with respect to services exceed 100% of the total cost of services provided hereunder.

Warranty Periods. Every claim by Buyer alleging a defect in the goods and/or services provided hereunder shall be deemed waived unless such claim is made in writing within the applicable warranty periods as set forth above. Provided, however, that if the defect complained of is latent and not discoverable within the above warranty periods, every claim arising on account of such latent defect shall be deemed waived unless it is made in writing within a reasonable time after such latent defect is or should have been discovered by Buyer.

Limitations / Exclusions. The warranties herein shall not apply to, and GAI-Tronics shall not be responsible for, any damage to the goods or failure of the services supplied hereunder, to the extent caused by Buyer's neglect, failure to follow operational and maintenance procedures provided with the equipment, or the use of technicians not specifically authorized by GAI-Tronics to maintain or service the equipment. **THE WARRANTIES AND REMEDIES CONTAINED HEREIN ARE IN LIEU OF AND EXCLUDE ALL OTHER WARRANTIES AND REMEDIES, WHETHER EXPRESS OR IMPLIED BY OPERATION OF LAW OR OTHERWISE, INCLUDING ANY WARRANTIES OF MERCHANTABILITY OR FITNESS FOR A PARTICULAR PURPOSE.**

Return Policy

If the equipment requires service, contact your Regional Service Center for a return authorization number (RA#). Equipment should be shipped prepaid to GAI-Tronics with a return authorization number and a purchase order number. If the equipment is under warranty, repairs or a replacement will be made in accordance with the warranty policy set forth above. Please include a written explanation of all defects to assist our technicians in their troubleshooting efforts.

Call 800-492-1212 (inside the USA) or 610-777-1374 (outside the USA) for help identifying the Regional Service Center closest to you.